

**256GB****256GB M.2 2280 NGFF Drive Datasheet**

(Based on NAND Flash)

**Version: 1.0**

**NOTE:** INFORMATION IN THIS PRODUCT SPECIFICATION IS SUBJECT TO CHANGE AT ANYTIME WITHOUT NOTICE. ALL PRODUCT SPECIFICATIONS ARE PROVIDED FOR REFERENCE ONLY. TO ANY INTELLECTUAL PROPERTY RIGHTS IN A-Ray PRODUCT OR TECHNOLOGY. ALL INFORMATION IN THIS DOCUMENT IS PROVIDED.

Kston Storage Technology(Dongguan) Co.,Ltd

Add:4/F, Bldg 1, YaLitong Industrial park, No. 162, Luyuan Rd, TangXia Town, DongGuan

# Table of Contents

Kston Storage Technology(Dongguan) Co.,Ltd

256GB .....	1
k765 -256GB M.2 2280 NGFF Drive Datasheet .....	1
I. Introduction .....	3
1 Overview .....	3
2 Part Type Introduction .....	3
Outline .....	4
II. Block Diagram .....	5
IV. Product Specifications .....	6
4.1 Physical Dimensions .....	6
4.2 Interface Specification .....	6
4.2.1 Pin Assignment .....	6
V. Reliability .....	7
5.1 ECC Descriptions .....	7
5.2 Advance Wear-Leveling Algorithm .....	7
5.3 S.M.A.R.T Function .....	7
VI. Ordering Information .....	7
VII. Related documentation .....	7
Attachment .....	7

Kston Storage Technology(Dongguan) Co.,Ltd

Add:4/F, Bldg 1, YaLitong Industrial park, No. 162, Luyuan Rd, TangXia Town, DongGuan

# I. Introduction

## 1 Overview

### 1 Overview

A-RAY SATA SSD (Solid State Drive) is a high performance and high reliability storage device based on NAND Flash technology that designed to solve the bottleneck of computing system by traditional hard disk drives. Our SATA SSD doesn't have a moving parts and it has a same host interface and same physical dimension with Hard Disk Drive, so it can be drop-in replaced with the hard disk drives without anything. With a high performance and low power consumption, Our SATA SSD can be a good storage device for NB and Tabletop PC.

**A-RAY** SATA SSD purely consists of semiconductor devices and NAND flash memories, which give rugged features against shock and vibration, used in extreme environment such as industrial PC to increase MTBF. Furthermore, Our SATA SSD has highly advanced flash memory management algorithm to guarantee

## 2 Part Type Introduction

This chapter is about the specifications of the M.2 NGFF SATA Solid State Drive SSD with SATA III interface.

Type	Capacity	Flash	Interface
K765	256GB	3D TLC	M.2 NGFF

Table 1 Capacity Specifications

Capacity	Available Capacity	R / W(MB/s)	Random R/W	IOPS
<b>256GB</b>	238.47GB	498/458	44796/72267	

Kston Storage Technology(Dongguan) Co.,Ltd

Add:4/F, Bldg 1, YaLitong Industrial park, No. 162, Luyuan Rd, TangXia Town, DongGuan

# Outline

<b>Based spec</b>	Interface		M.2 NGFF
	Dimension		80*22*0.8 mm
	Weight ①		5.6g
	Capacity		256GB
	Controller		SMI2258XT
	Flash type		3D TLC NAND Flash
<b>Read/Write Performance ②</b>	CDM Sequential Read		Up to 550MB/s
	CDM Sequential Write		Up to 500MB/s
	ATTO Sequential Read		Up to 500MB/s
	ATTO Sequential Write		Up to 450MB/s
<b>Power Consumption</b>	Power Supply		5V±5%
	Standby		0.3W
	Maximum Ripple		70 mV(peak to peak)
	4KB Random Write		2.5W
<b>Reliability</b>	Write endurance:3years @ 100G write/day		
	Read endurance: unlimited		
	MTBF: >1,000,000 hours		
	Data retention: >20years @ 25°C		
	Data destroy do not support		
	Sudden power-off recovery support		
	S.M.A.R.T,NCQ,Trim and dynamic power management support		
	Static and dynamic wear-leveling		
	Bad block management algorithm		
	ECC: LDPC ECC		
<b>Environment</b>	Storage temperature: -55~95 °C		
	Operation temperature: 0~75°C		
	Humidity: 5%~95%		
	Vibration	15G (10 to 2000Hz)	
	Shock	350G at 0.5ms	
<b>Warranty</b>	3 years		

Table 2 outline of the driver

①, ②: The Read/Write performance and weight vary with different capacity of products.

Kston Storage Technology(Dongguan) Co.,Ltd

Add:4/F, Bldg 1, YaLitong Industrial park, No. 162, Luyuan Rd, TangXia Town, DongGuan

The testing environment is below:

OS: Windows 7 Ultimate

CPU: Intel (R) Core(TM) i3-2100T CPU @2.50GHz

Memory: 4GB

Motherboard: Controller:SMI2258XT,SATA III,256GB SSD

Test program: ATTO Disk BenchMark ; CrystalDiskMark

Test Drive: k765 256GB (3D TLC)

## II.Block Diagram

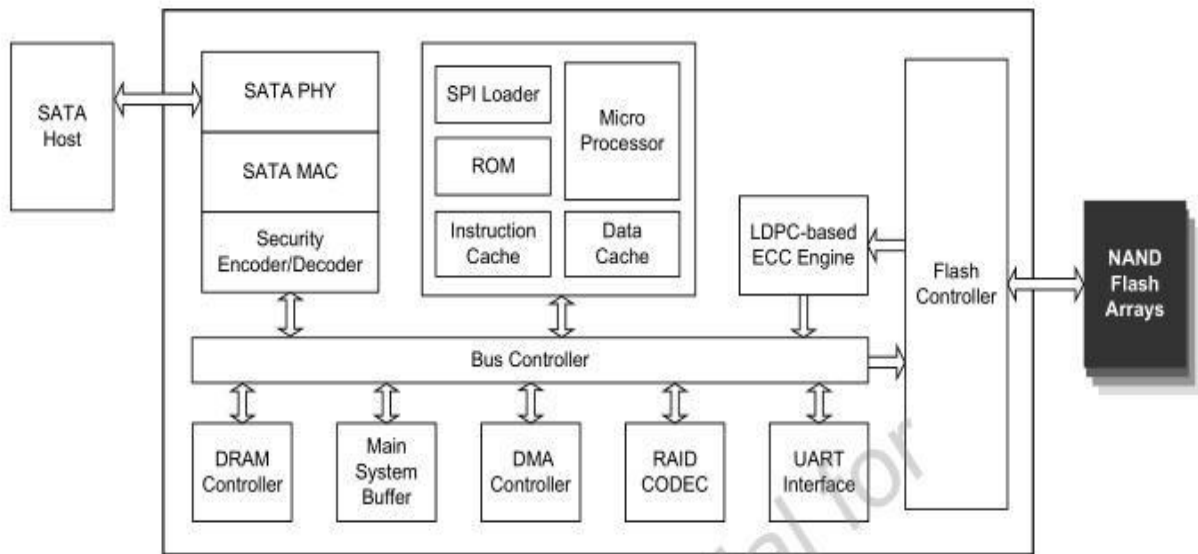

Figure 1 SMI2258XT Block Diagram

## IV. Product Specifications

### 4.1 Physical Dimensions

Parameter	Value
Length	80mm
width	22 mm
height	0.8+0.1 mm

Table 3 Physical dimensions of the driver

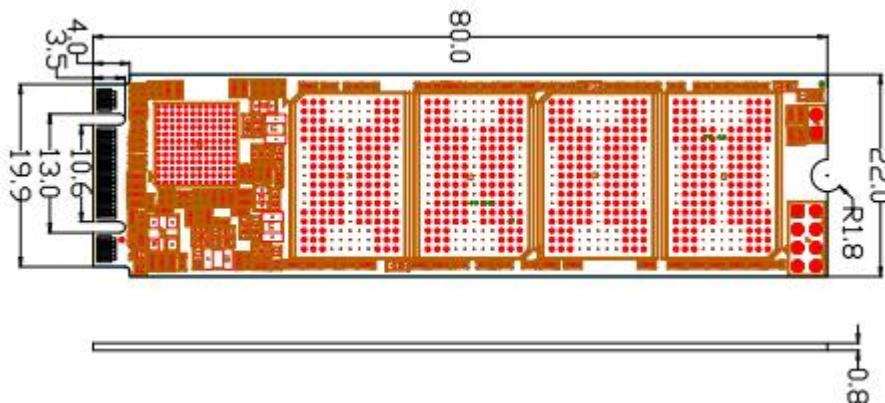

Figure 2 Physical dimensions

### 4.2 Interface Specification

#### 4.2.1 Interface Mode

The interface of the M.2 NGFF SSD complies with the standard Serial ATA version 3.1:

- ① Host Transfer Rate is 600MB/s(6.0Gb/s)
- ② PIO mode 0,1,2,3,4
- ③ DMA mode 0,1,2
- ④ UDMA mode 0,1,2,3,4,5,6

## V. Reliability

### 5.1 ECC Descriptions

The LDPC ECC engine executes parity generation and error detection/correction features, and enhances decoding throughput and data reliability. With LDPC of correction capacity 1e-2 RBER, the hard and soft decoding mechanism provides powerful error correction. Hence the SMI2258XT can enhance the endurance and retention of 3D TLC Nand Flash and extends the SSD lifespan.

### 5.2 Advance Wear-Leveling Algorithm

The NAND flash devices are limited by a certain number of write cycles. When using a file system, frequent file table updates is mandatory. If some area on the flash wears out faster than others, it would significantly reduce the lifetime of the whole device, even if the erase counts of others are far from the write cycle limit. Thus, if the write cycles can be distributed evenly across the media, the lifetime of the media can be prolonged significantly. The scheme is achieved both via buffer management and specific advanced wear leveling to ensure that the lifetime of the flash media can be increased, and the disk access performance is optimized as well.

### 5.3 S.M.A.R.T Function

S.M.A.R.T. is an acronym for Self-Monitoring, Analysis and Reporting Technology, an open standard allowing disk drives to automatically monitor their own health and report potential problems. It protects the user from unscheduled downtime by monitoring and storing critical drive performance and calibration parameters. Ideally, this should allow taking proactive actions to prevent impending drive failure. SMART feature adopts the standard SMART command B0h to read data from the drive. When the SMART Utility running on the host, it analyzes and reports the disk status to the host before the device is in critical condition.

## VI. Ordering Information

Model	Capacity	PN
K765	256GB	K765 256GB

## VII. Related documentation

For more information, Pls contact me : [linda@arayworld.com](mailto:linda@arayworld.com)

## Attachment

Test platform:

Kston Storage Technology(Dongguan) Co.,Ltd

Add:4/F, Bldg 1, YaLitong Industrial park, No. 162, Luyuan Rd, TangXia Town, DongGuan

System : Windows 10

CPU: Intel (R) Core(TM) CPU G3930@2.90GHz

Memory : 4GB

Mother Board: Controller:SMI2258XT,SATA III,256GB

Test SSD:Controller:SMI2258XT,SATA III,K765 256GB

Test performance picture:

### ATTO Disk Benchmark

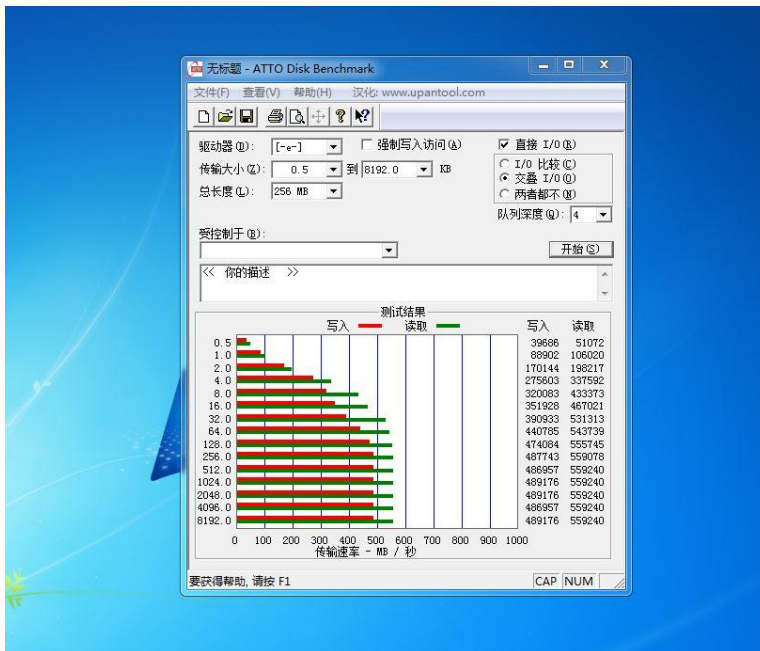

Kston Storage Technology(Dongguan) Co.,Ltd

Add:4/F, Bldg 1, YaLitong Industrial park, No. 162, Luyuan Rd, TangXia Town, DongGuan

### AS SSD benchmark

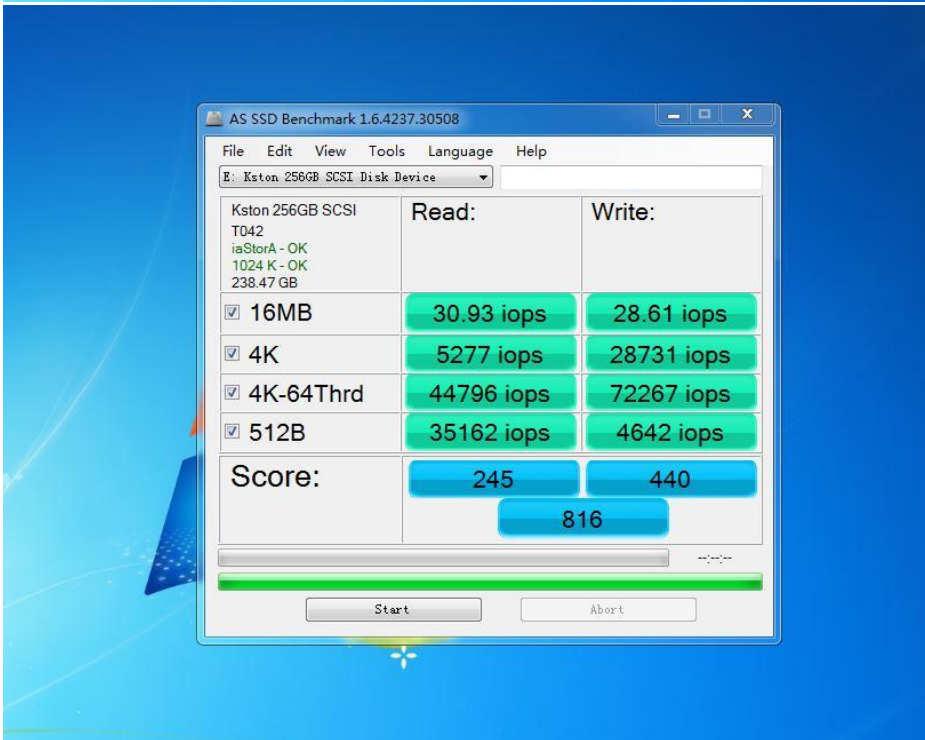
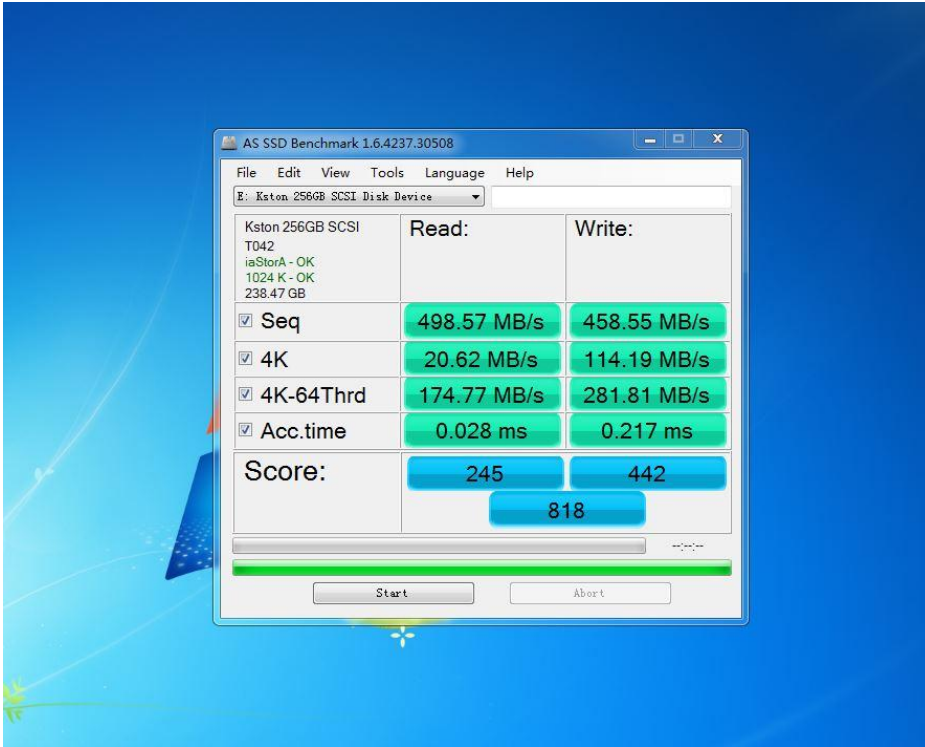

Kston Storage Technology(Dongguan) Co.,Ltd

Add:4/F, Bldg 1, YaLitong Industrial park, No. 162, Luyuan Rd, TangXia Town, DongGuan

## Crystal Disk Mark

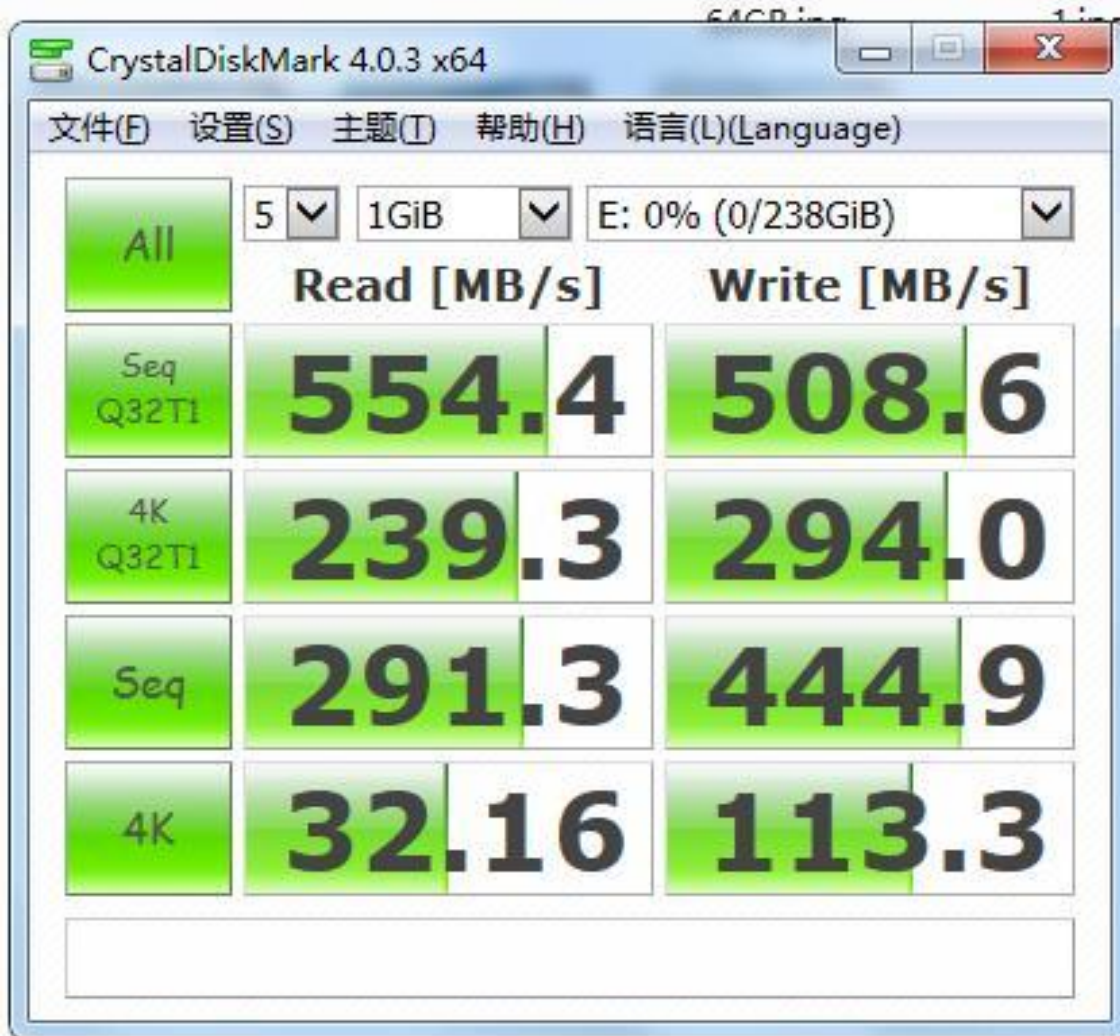

Kston Storage Technology(Dongguan) Co.,Ltd

Add:4/F, Bldg 1, YaLitong Industrial park, No. 162, Luyuan Rd, TangXia Town, DongGuan